

Comfort 150 DC / 160 DC

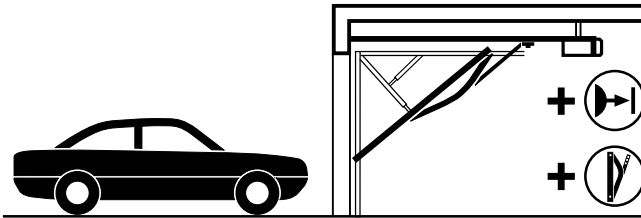

 SYSTEM ROTALINE[®]

1

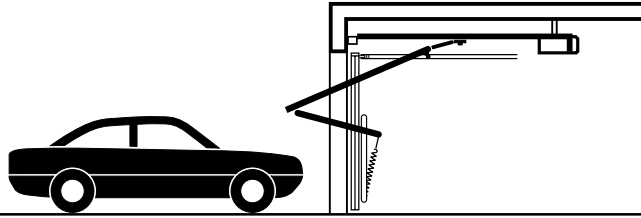
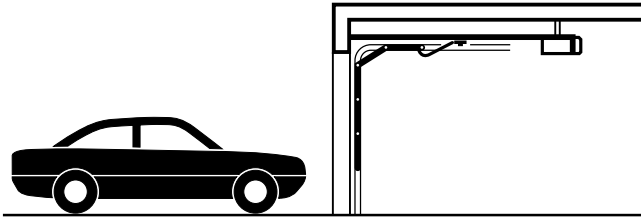

= Special 601; Art.-Nr. 564 266

= Special 102; Art.-Nr. 564 865

2



3

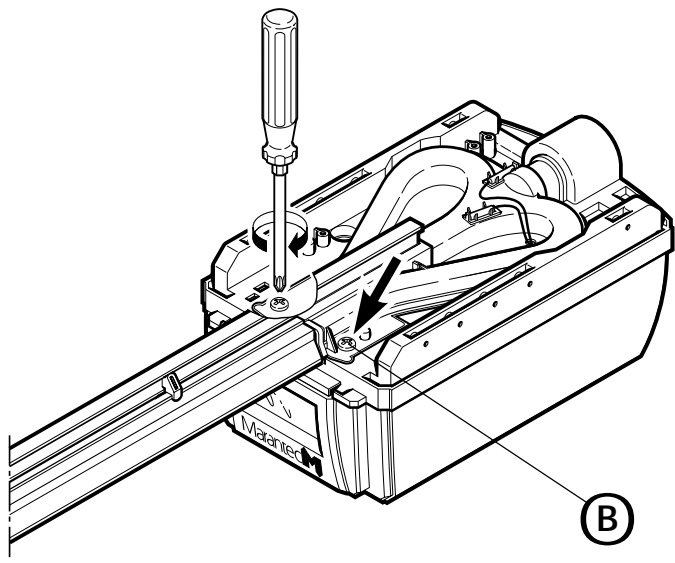
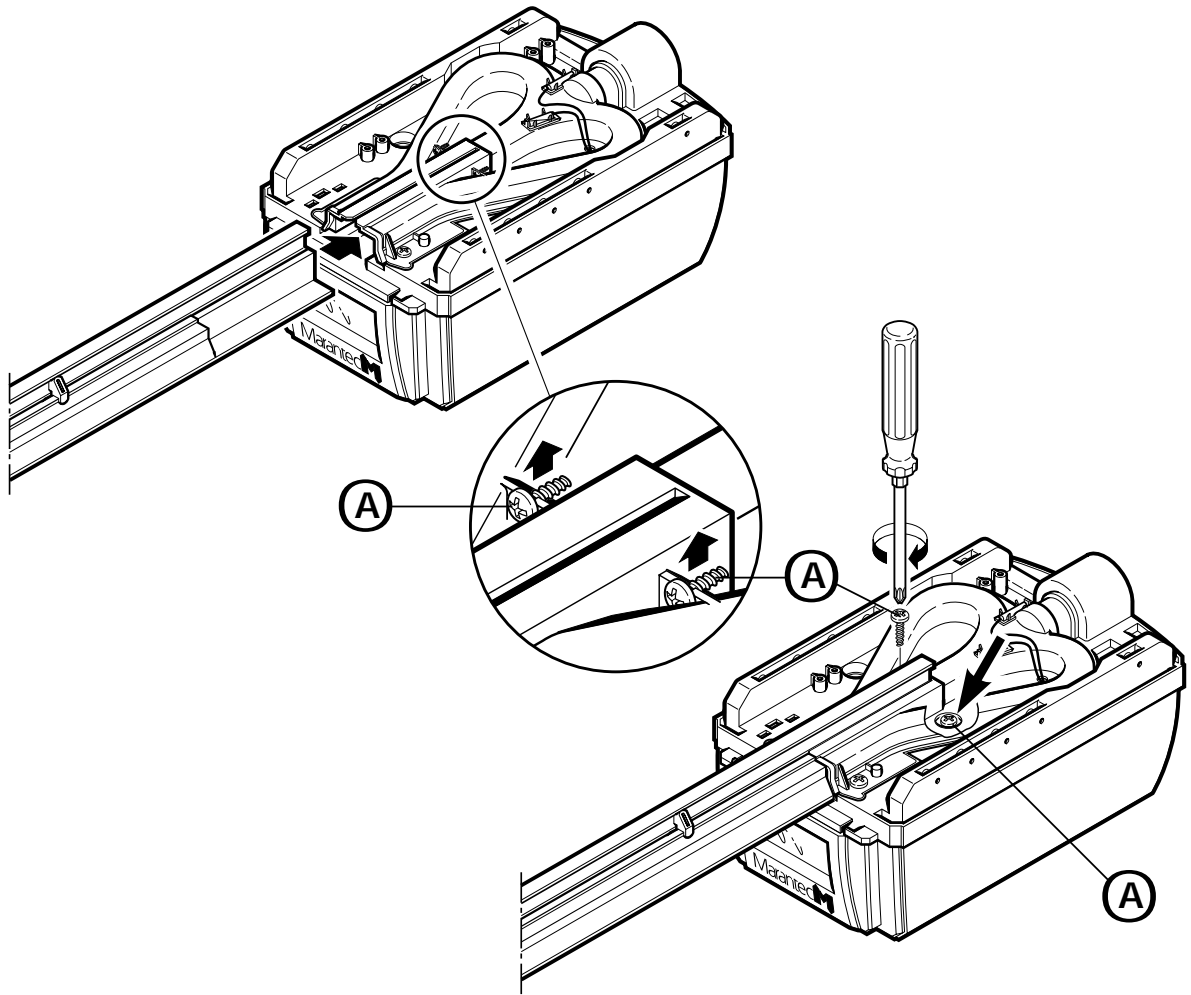

4

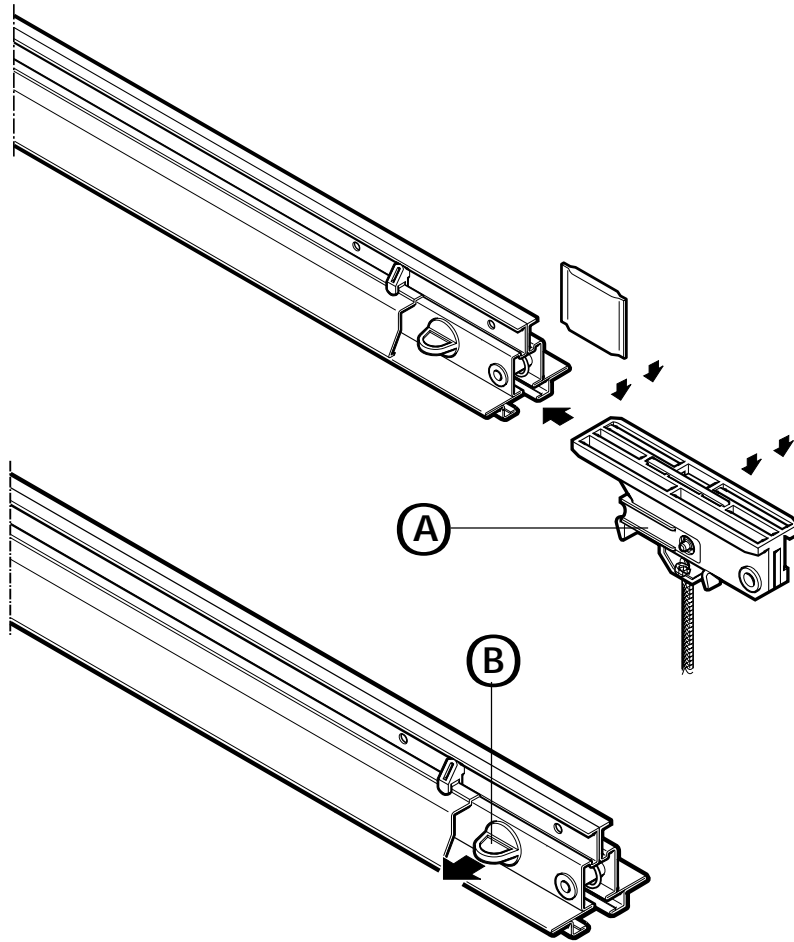

5

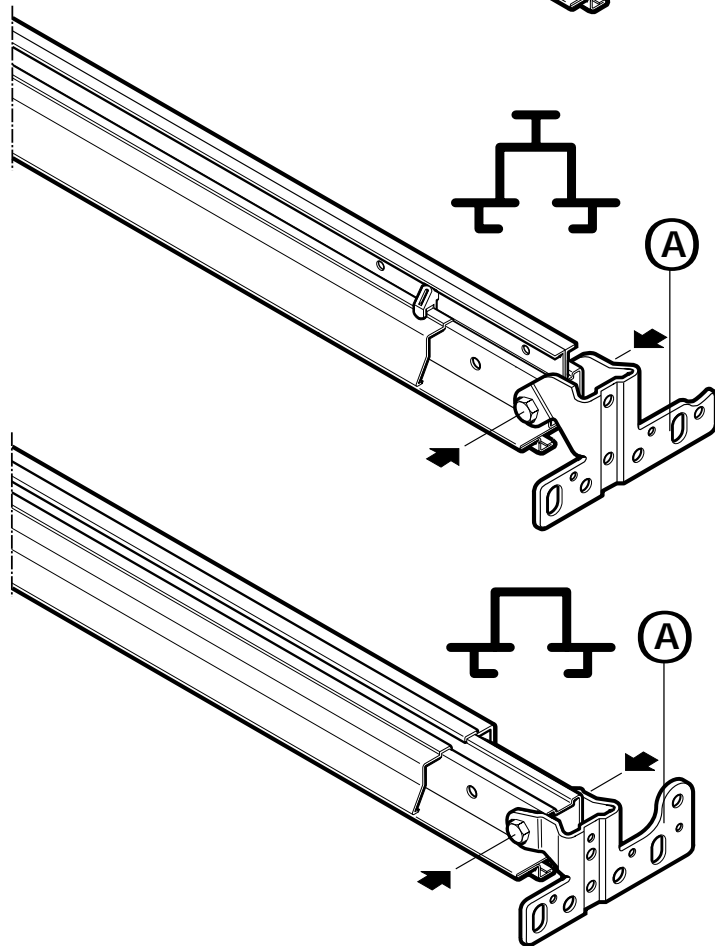

6

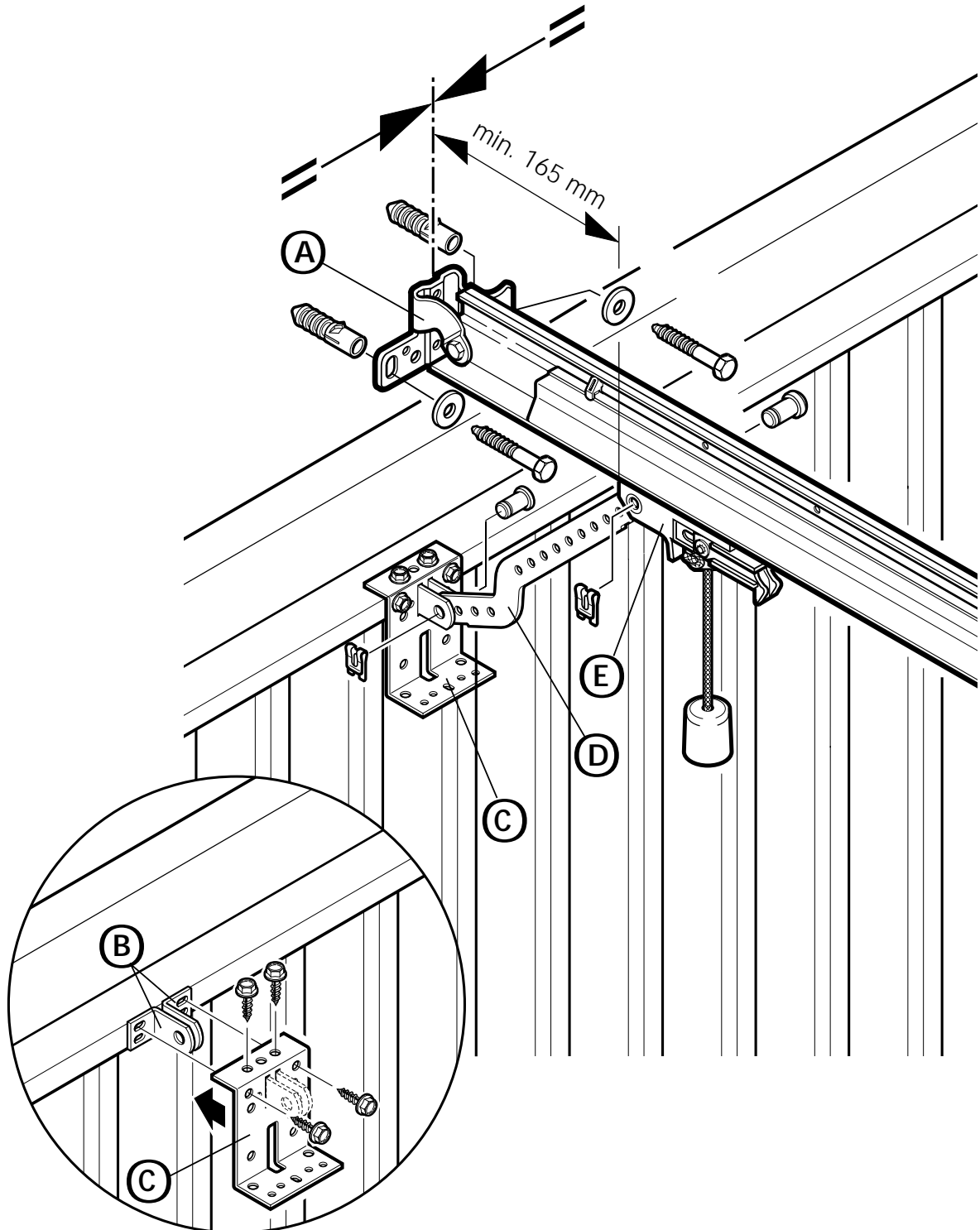
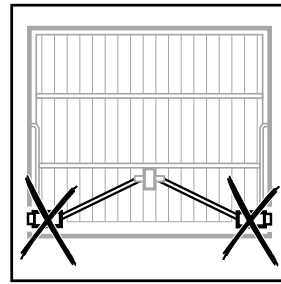
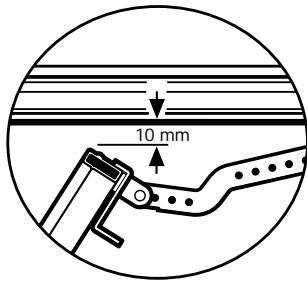
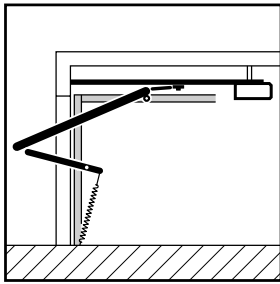

7

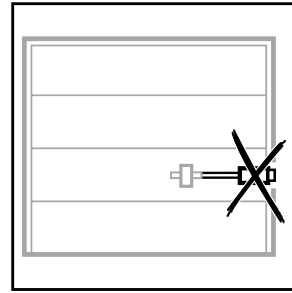
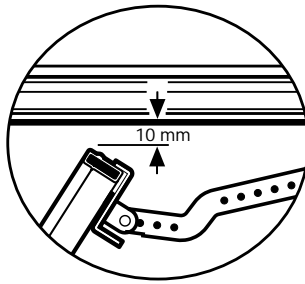
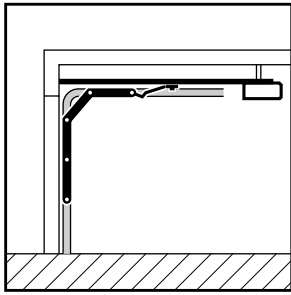

7.1

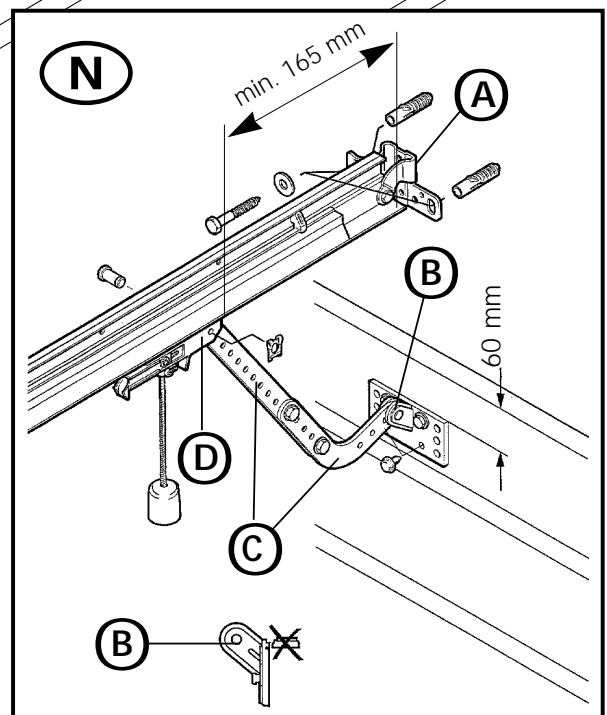
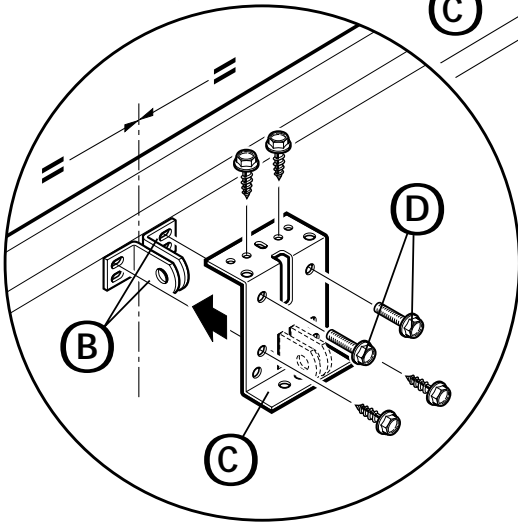
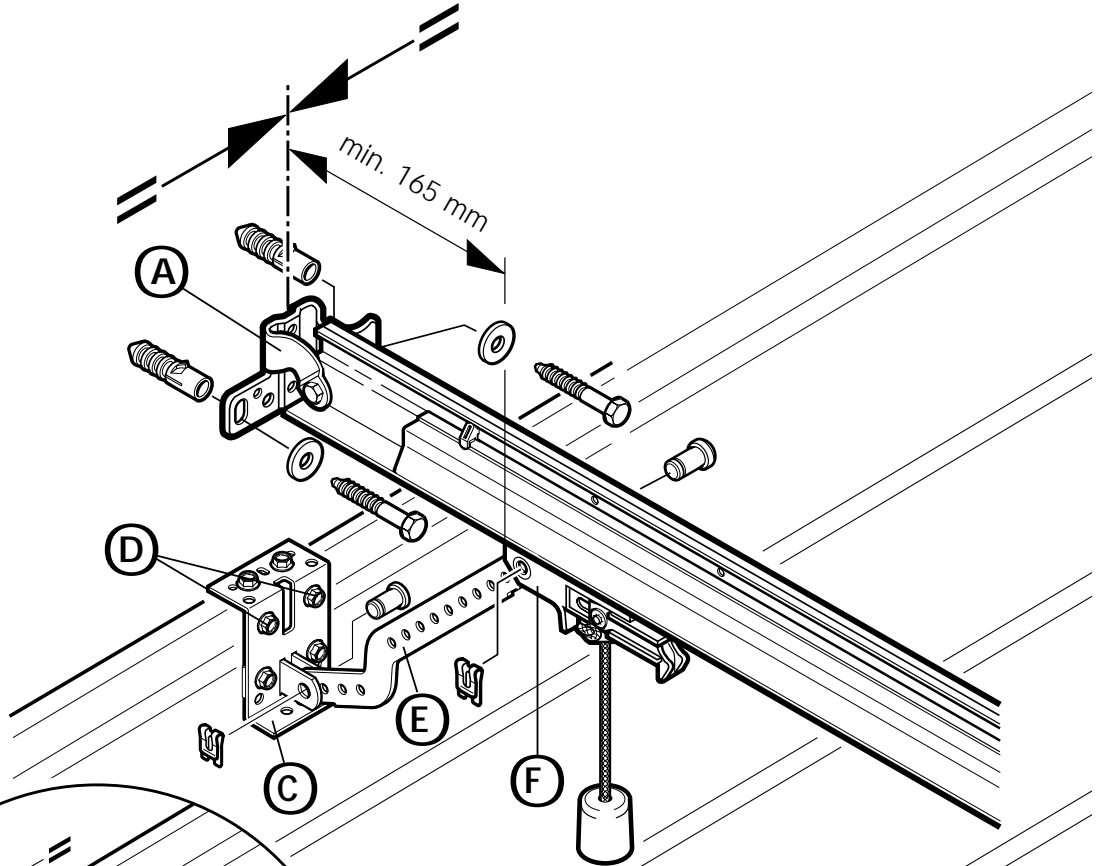

7.2

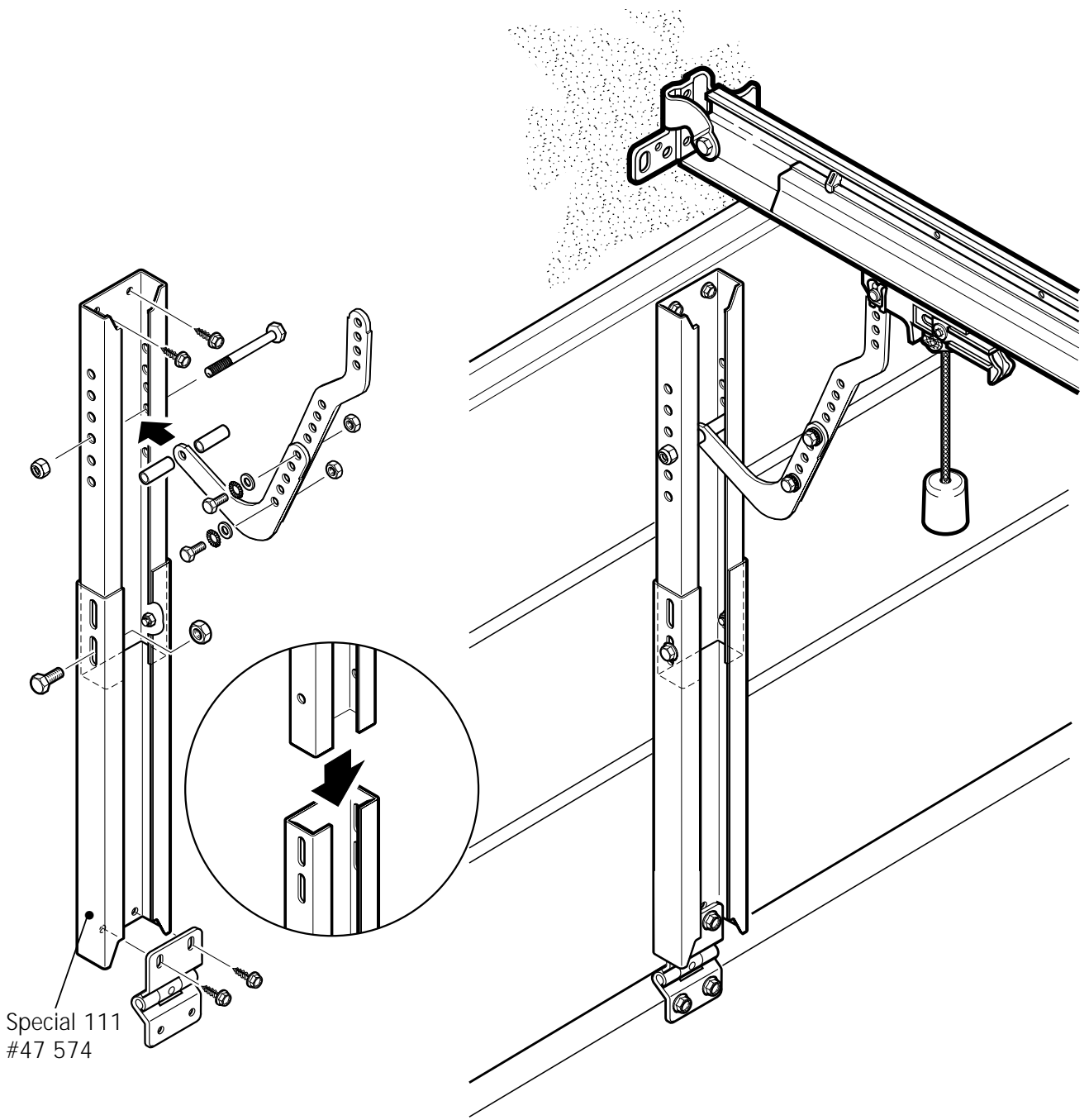

8

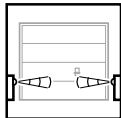
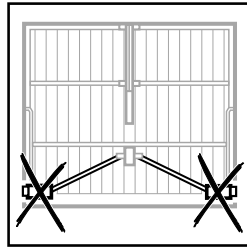
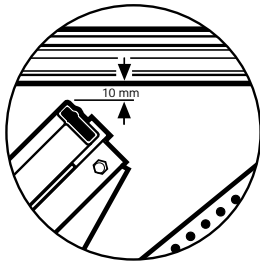
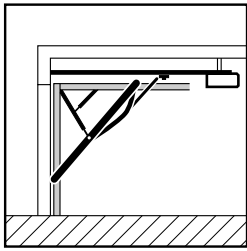

= Special 601; Art.-Nr. 564 266

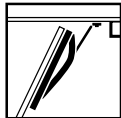

= Special 102; Art.-Nr. 564 865

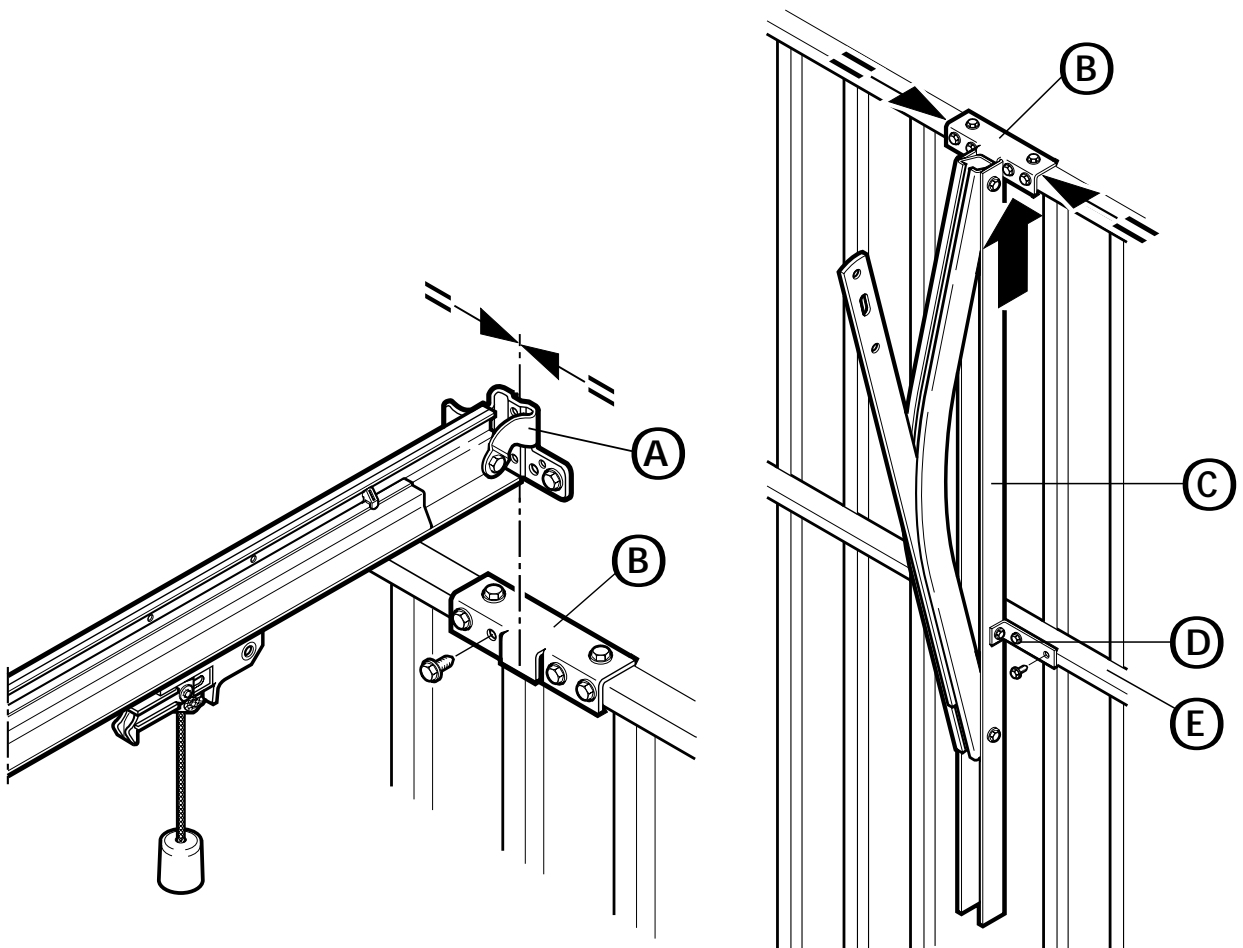

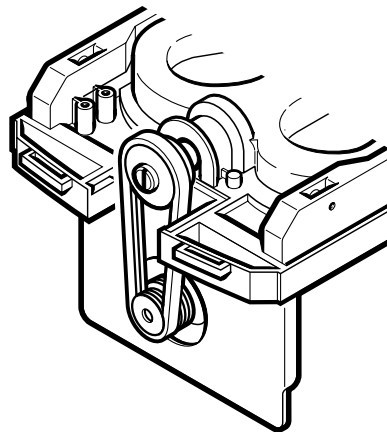
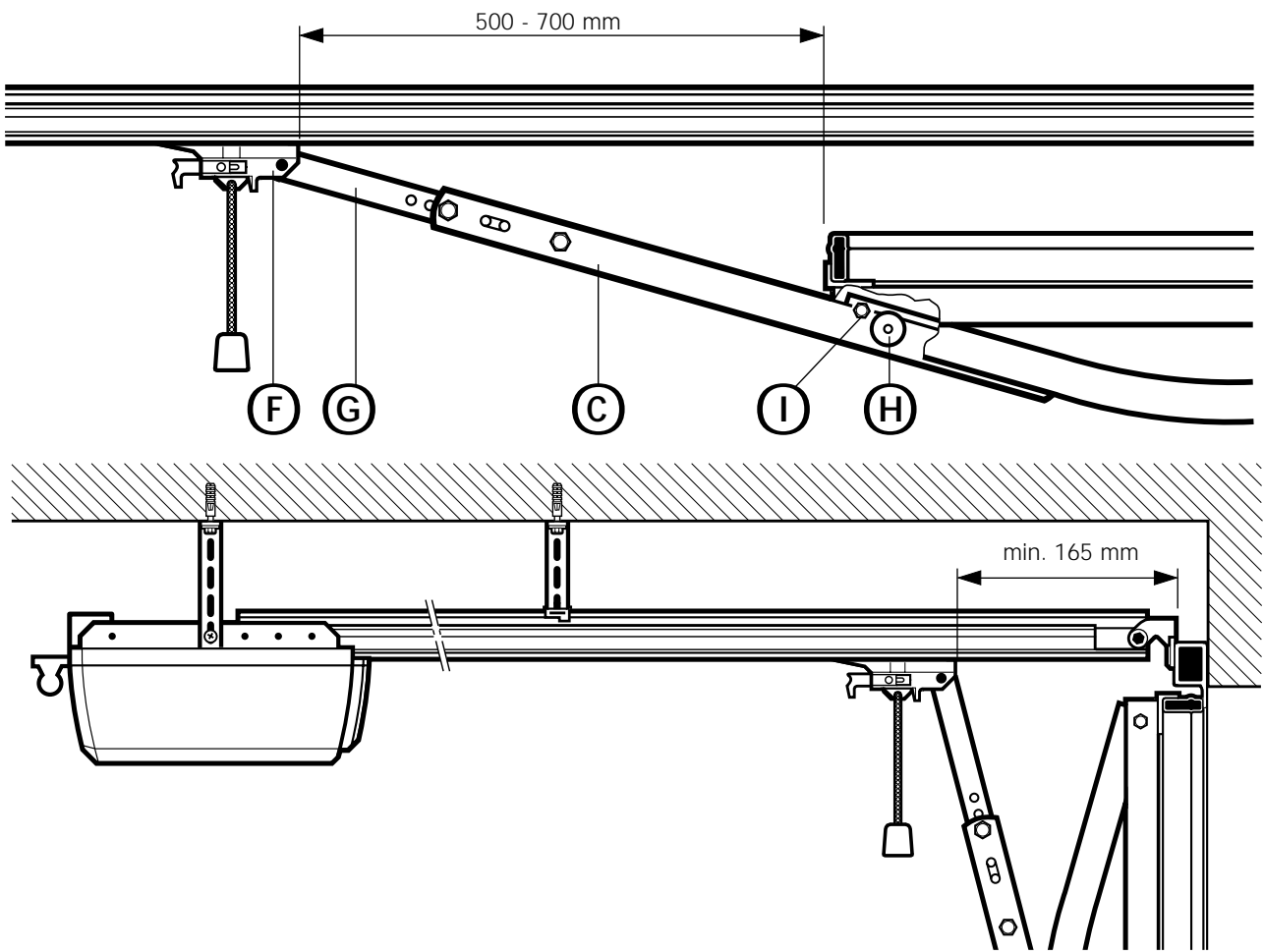

9

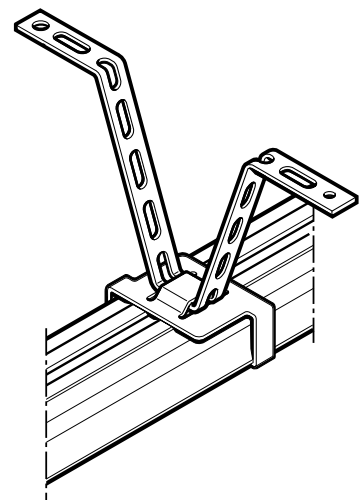
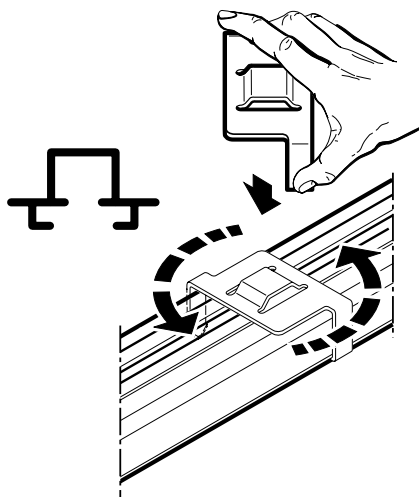
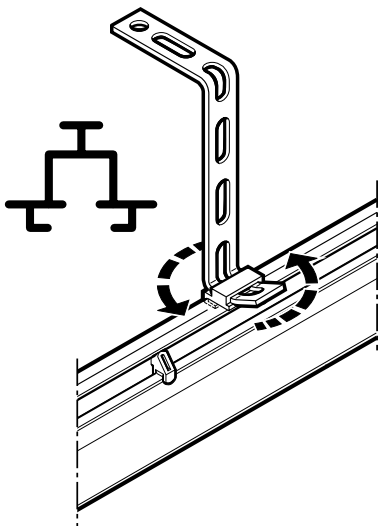
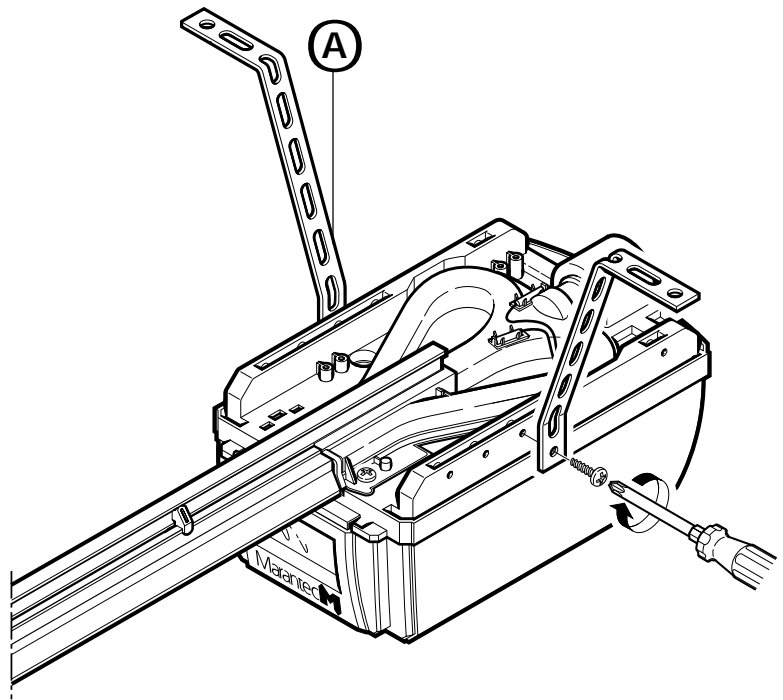

10

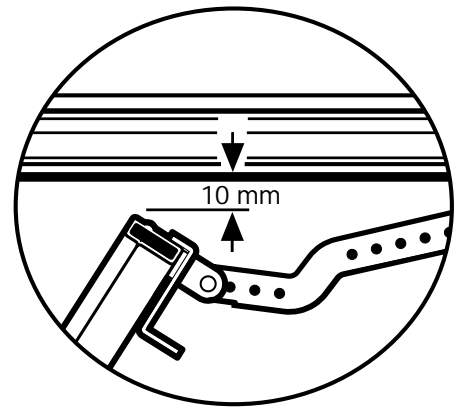
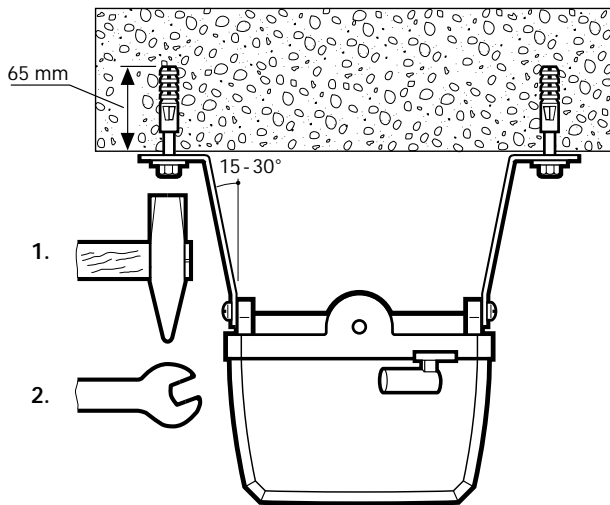
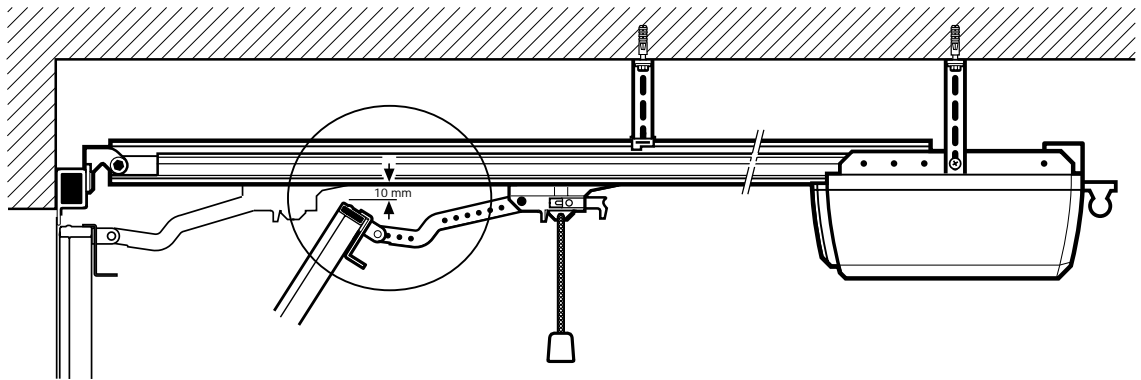

11

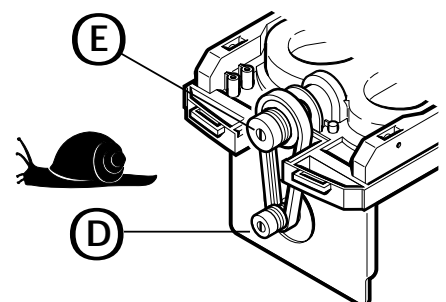
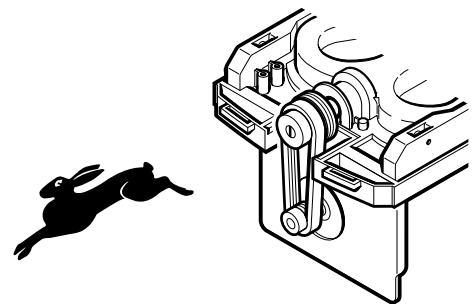
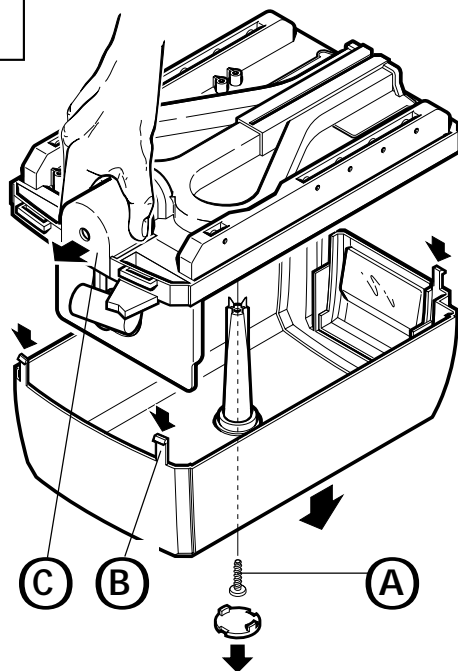
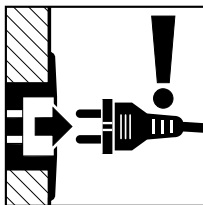

12

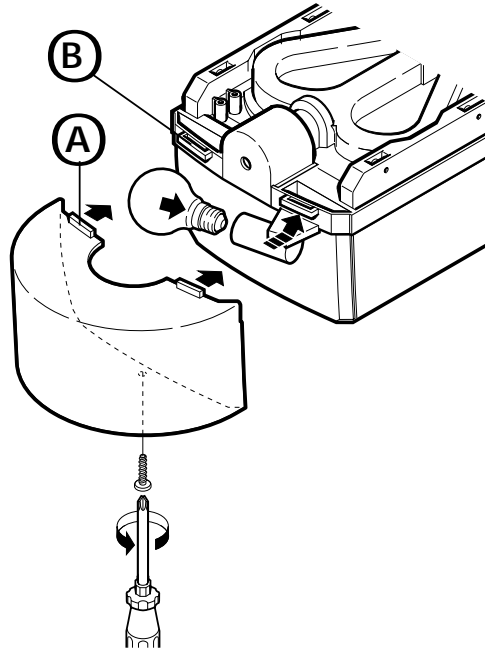

13

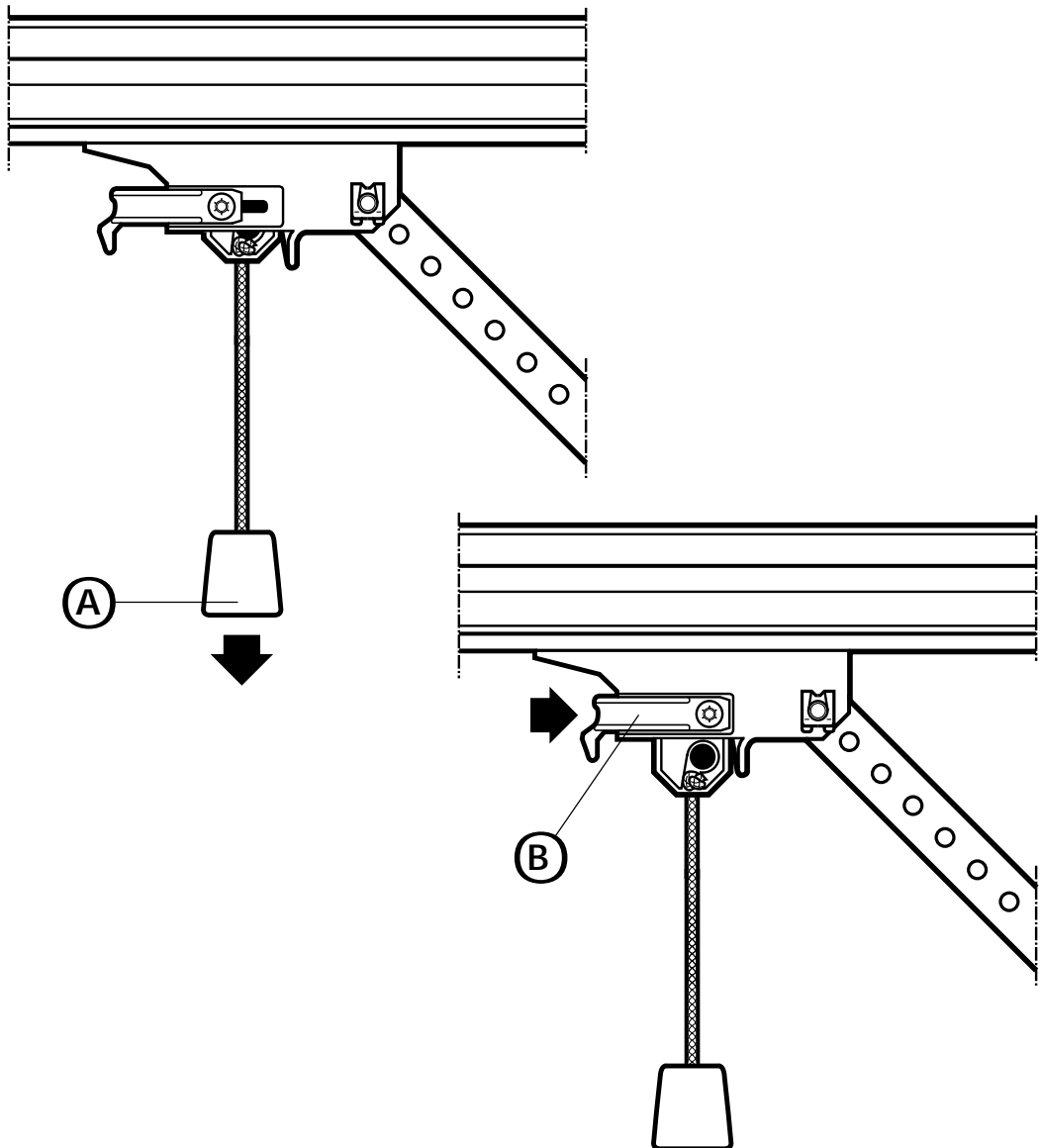

14

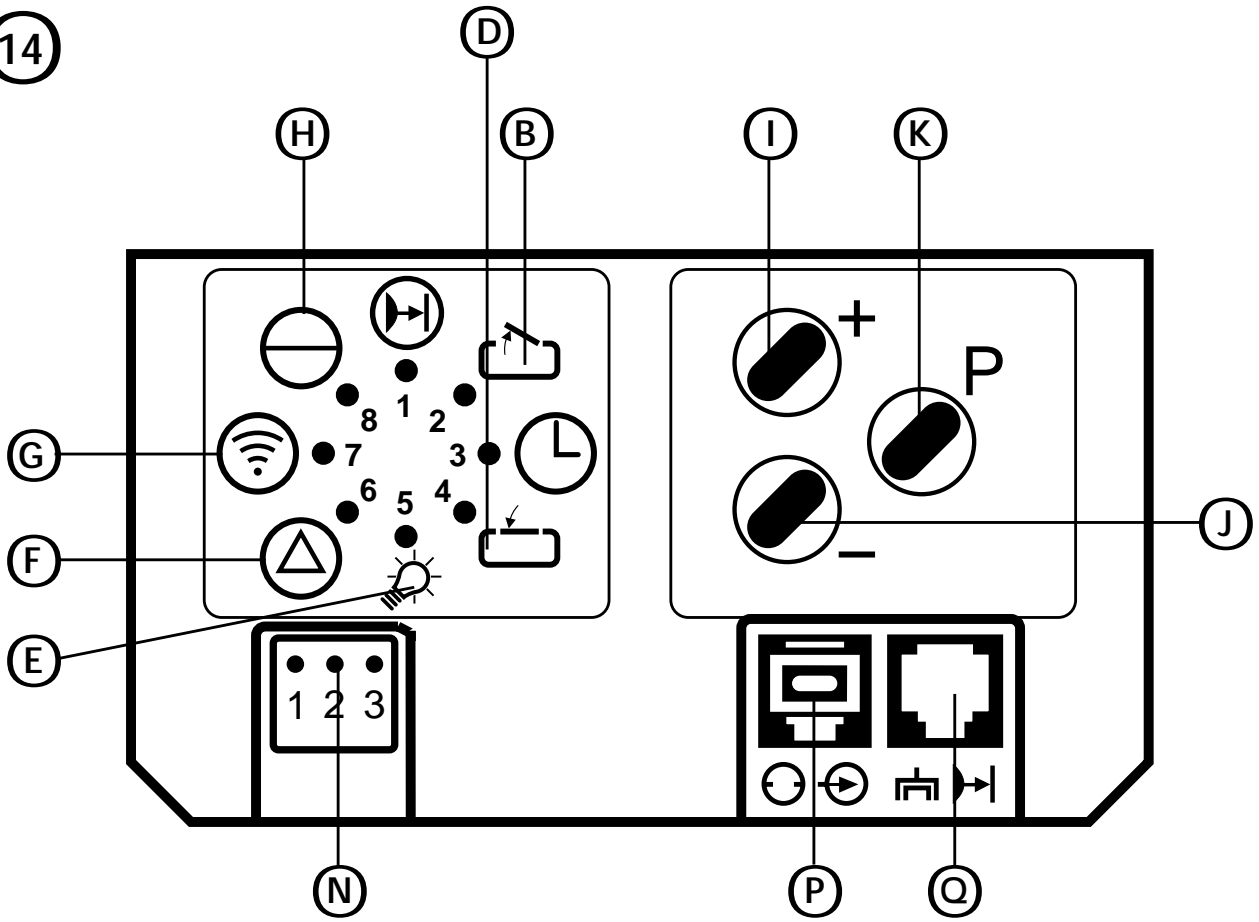

15

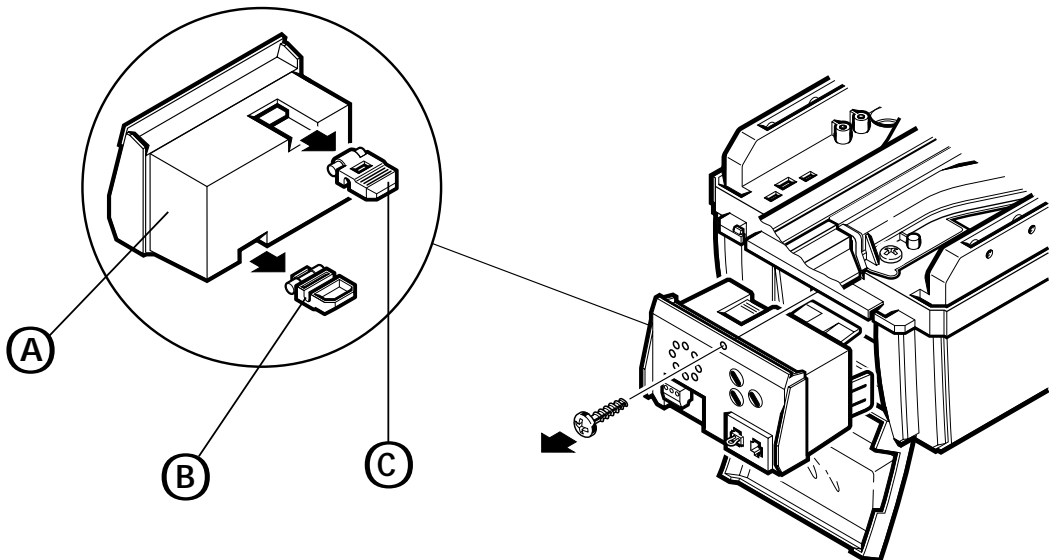

16

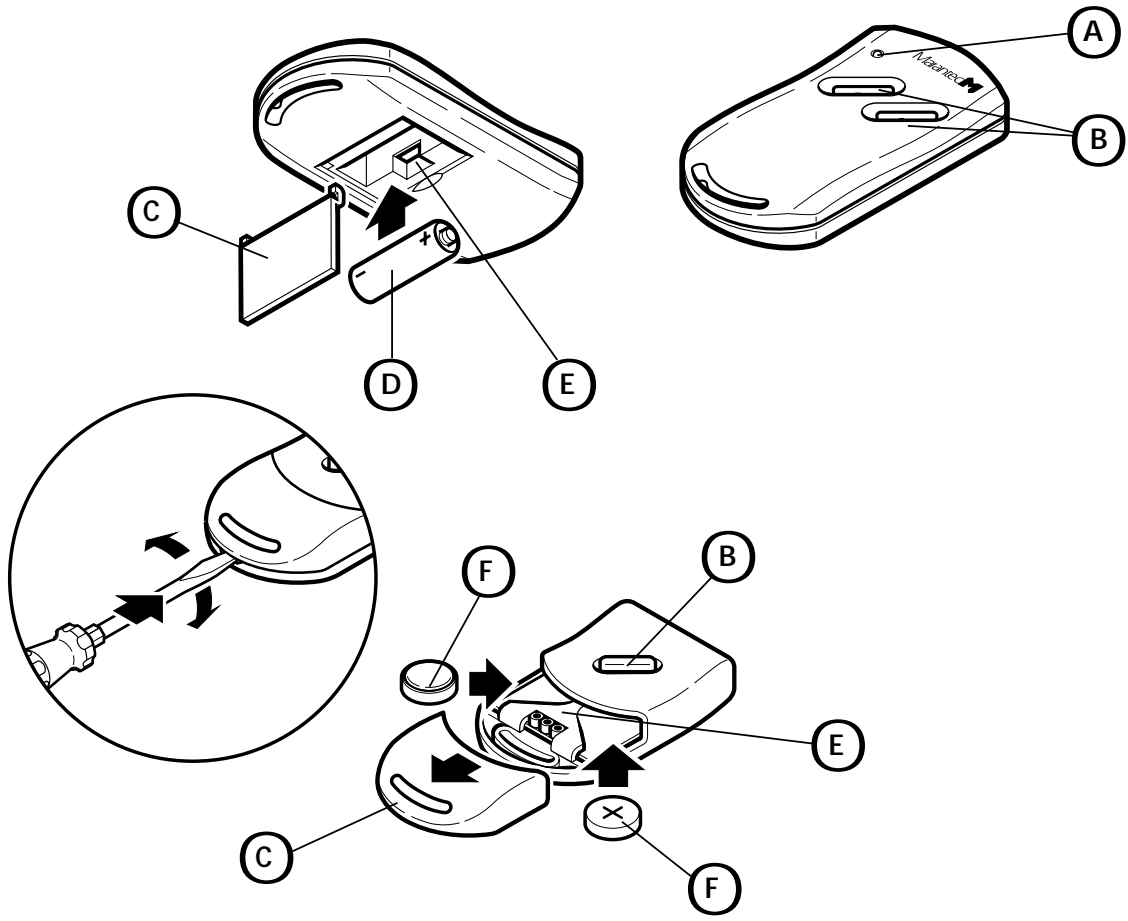

A

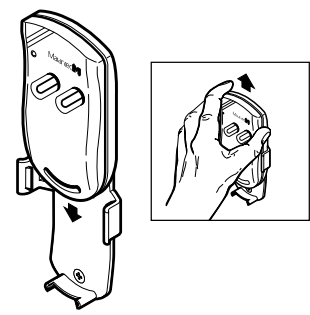
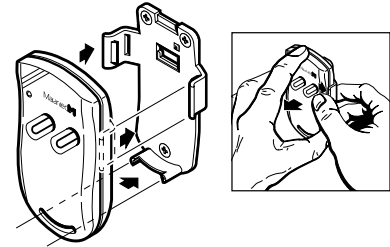
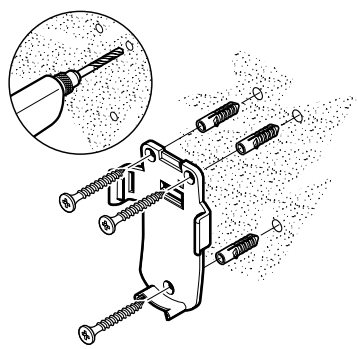

B

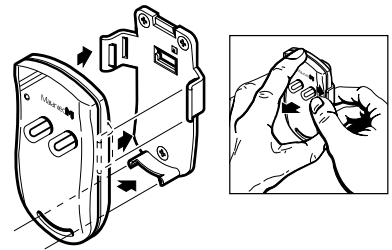
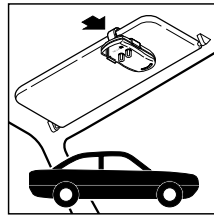
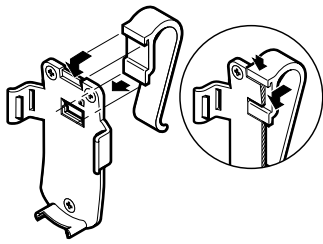

C

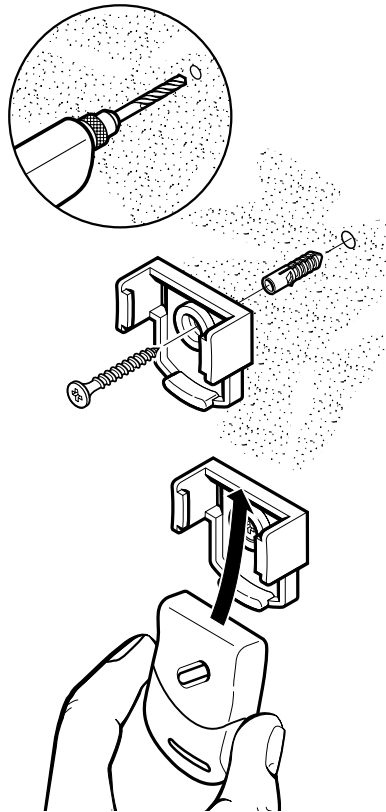

D

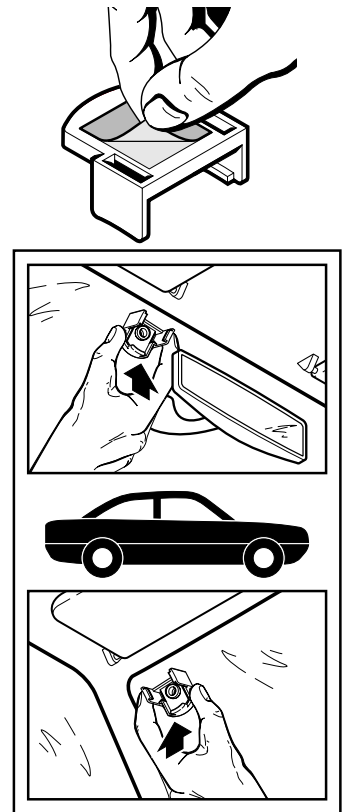

17

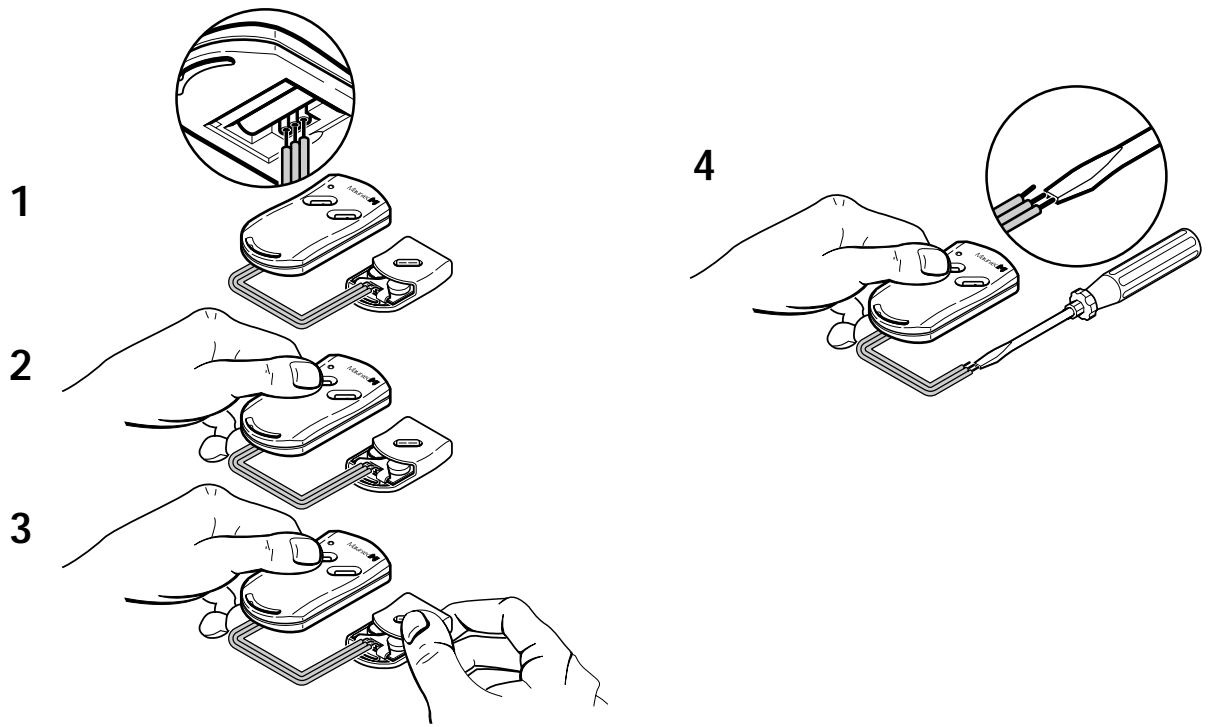

18

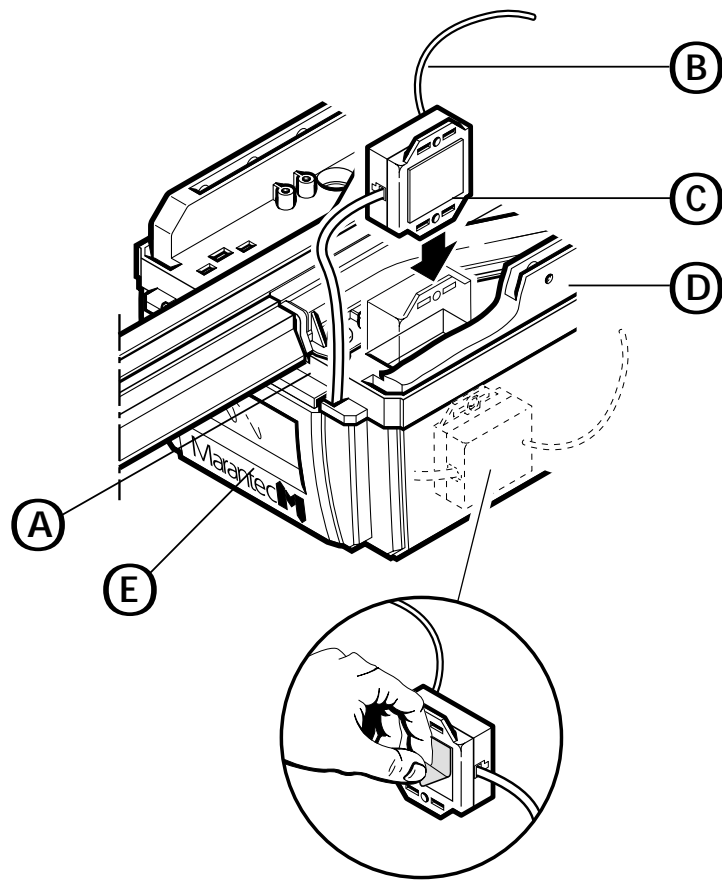

19

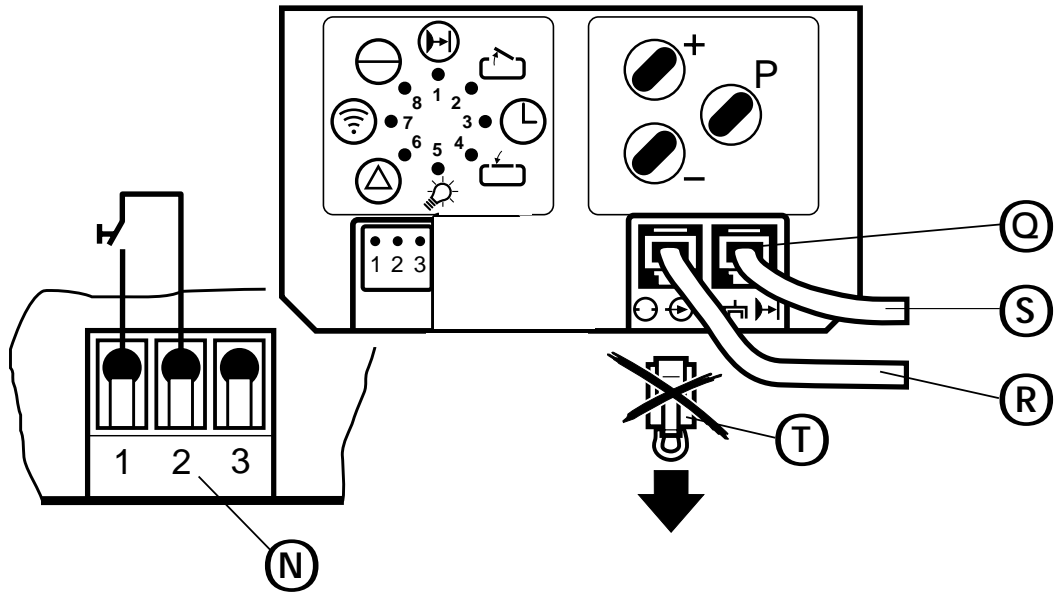

20

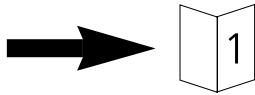

21

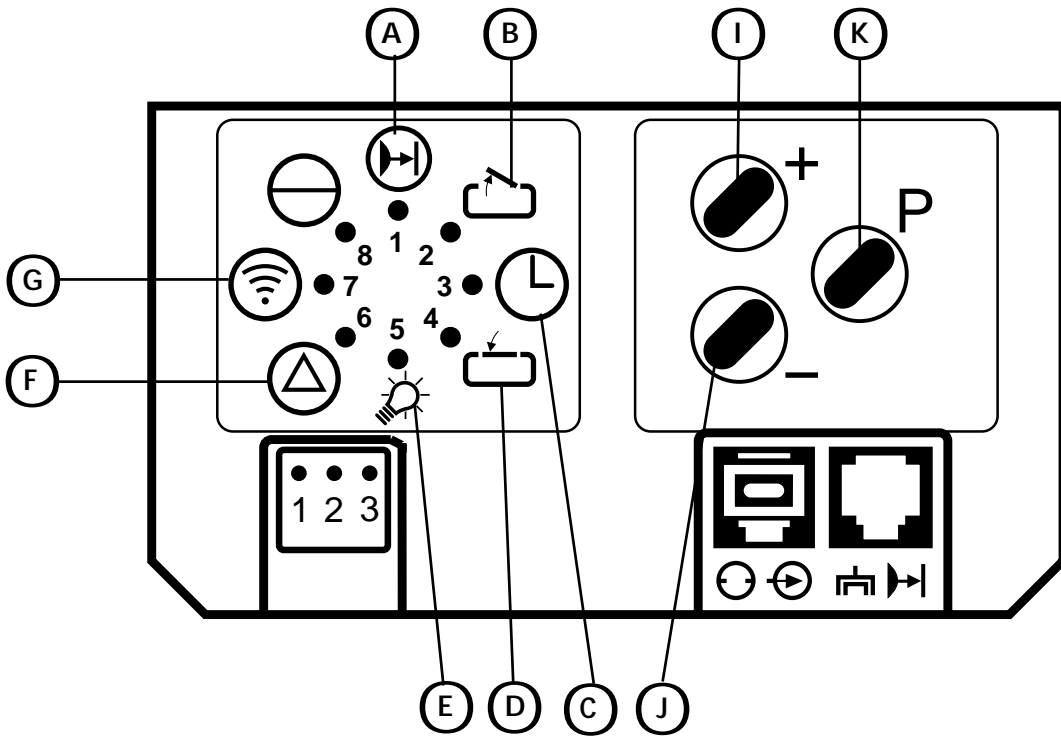

22

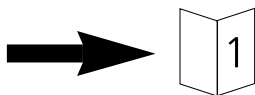

23

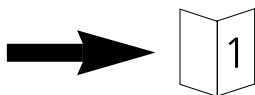

24

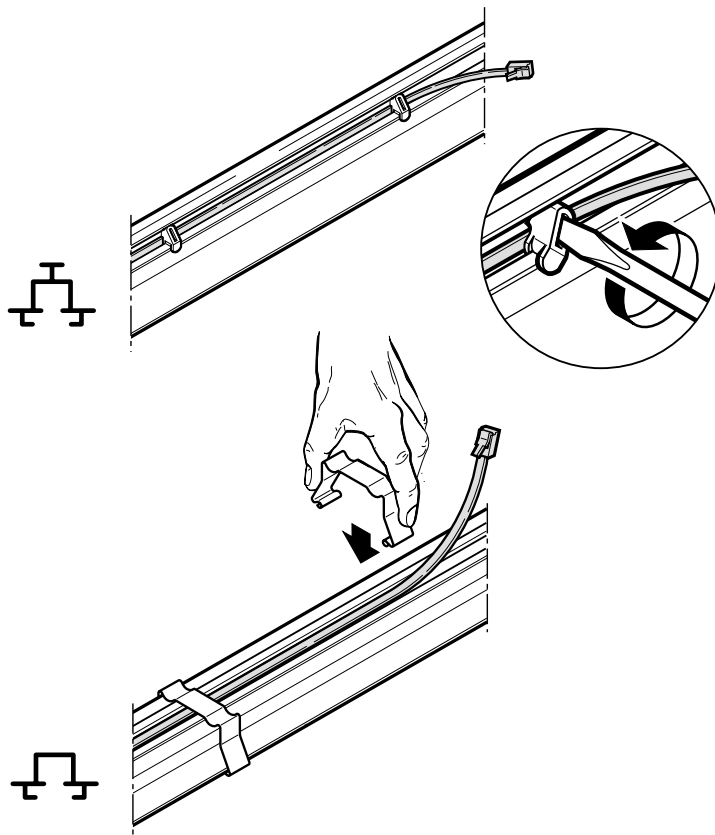
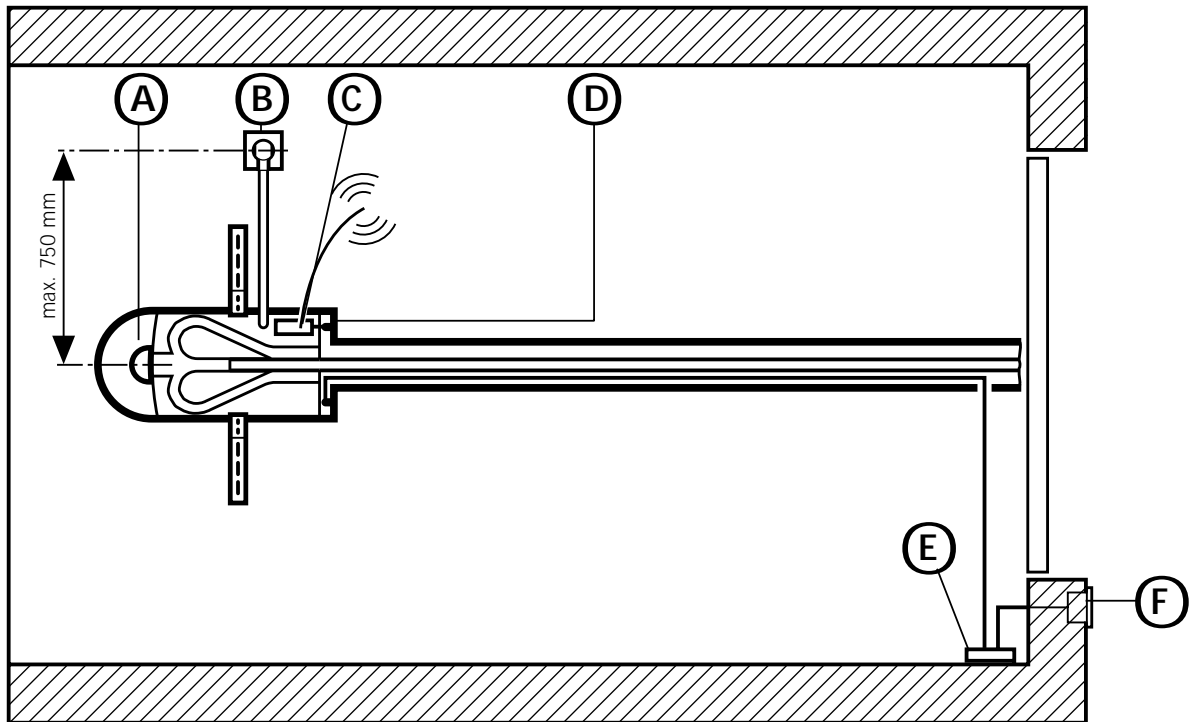

25

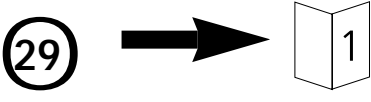
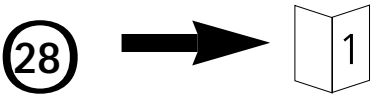
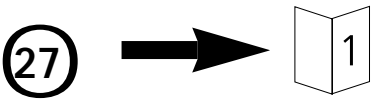
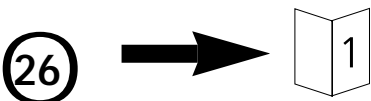
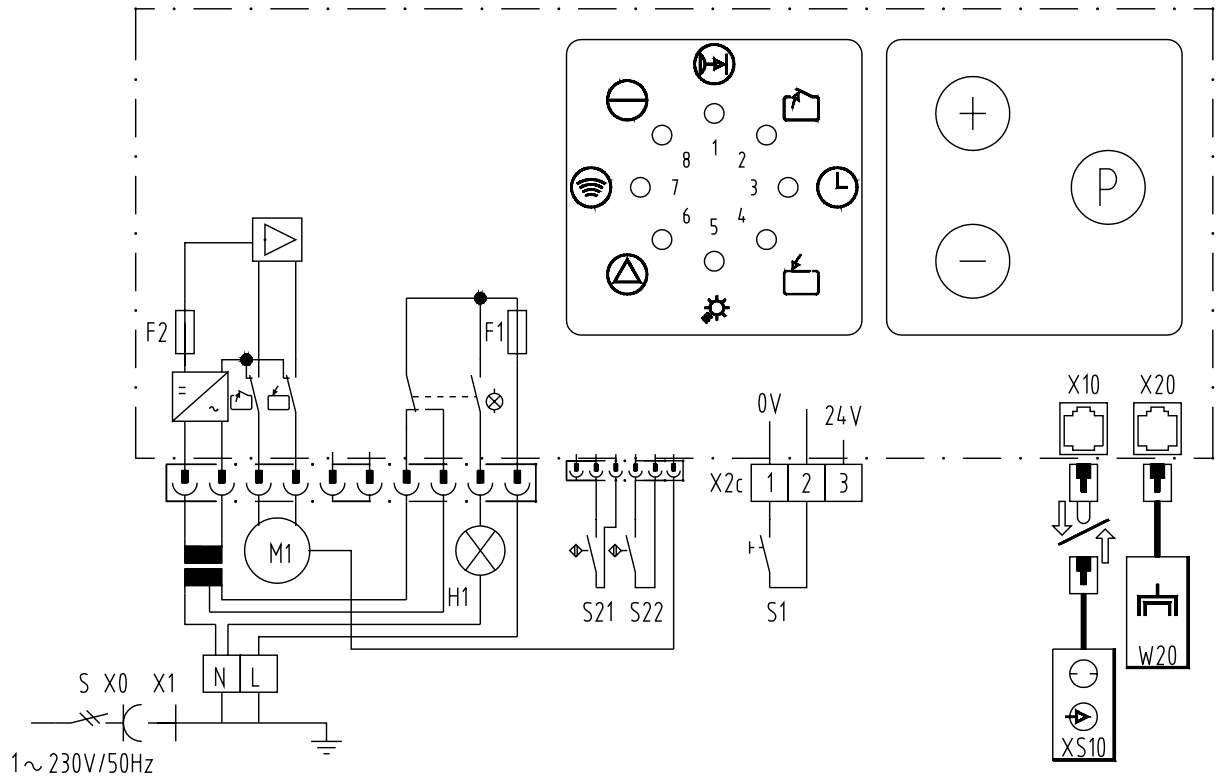

Comfort 150/160 DC

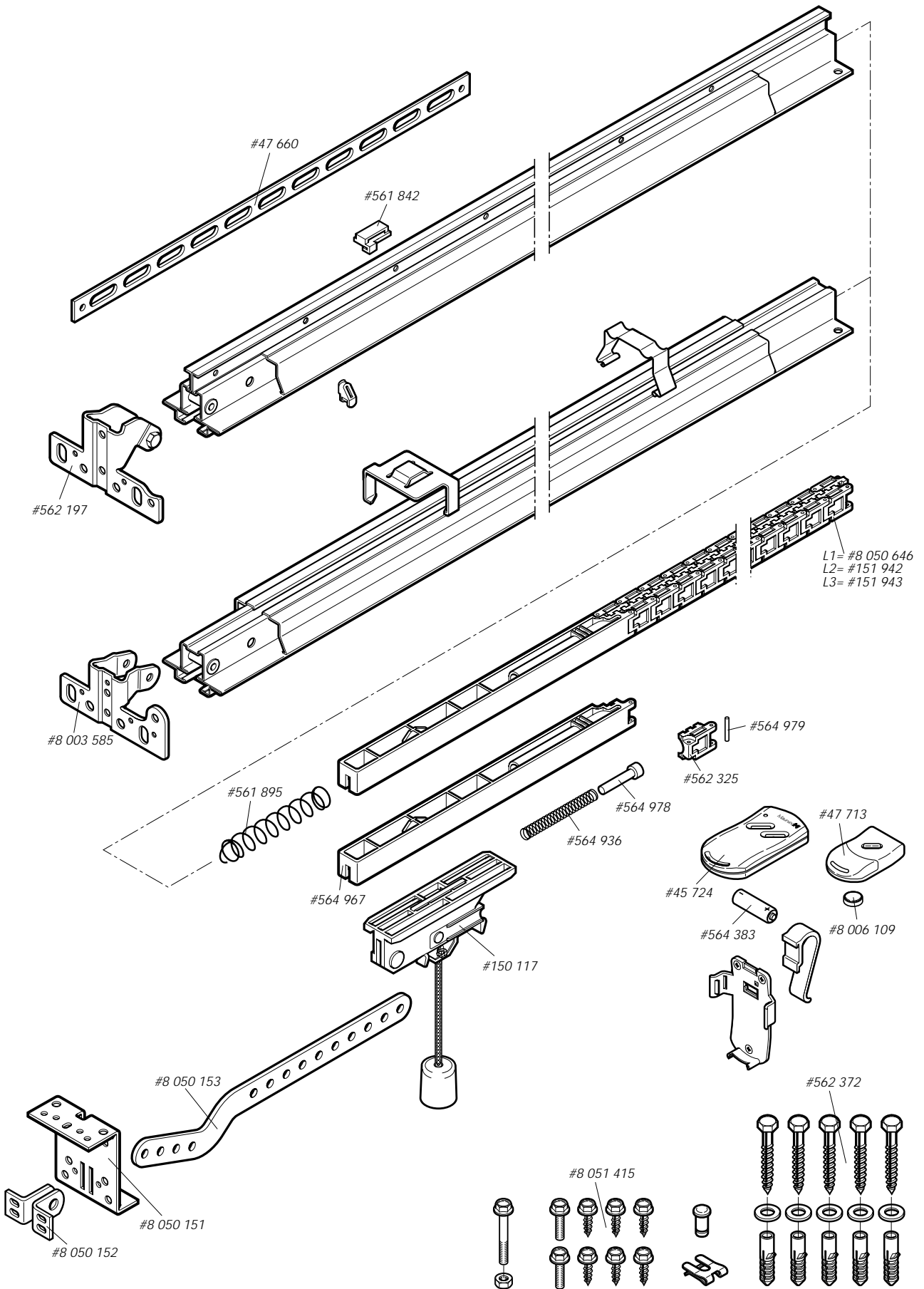

Comfort 150/160 DC

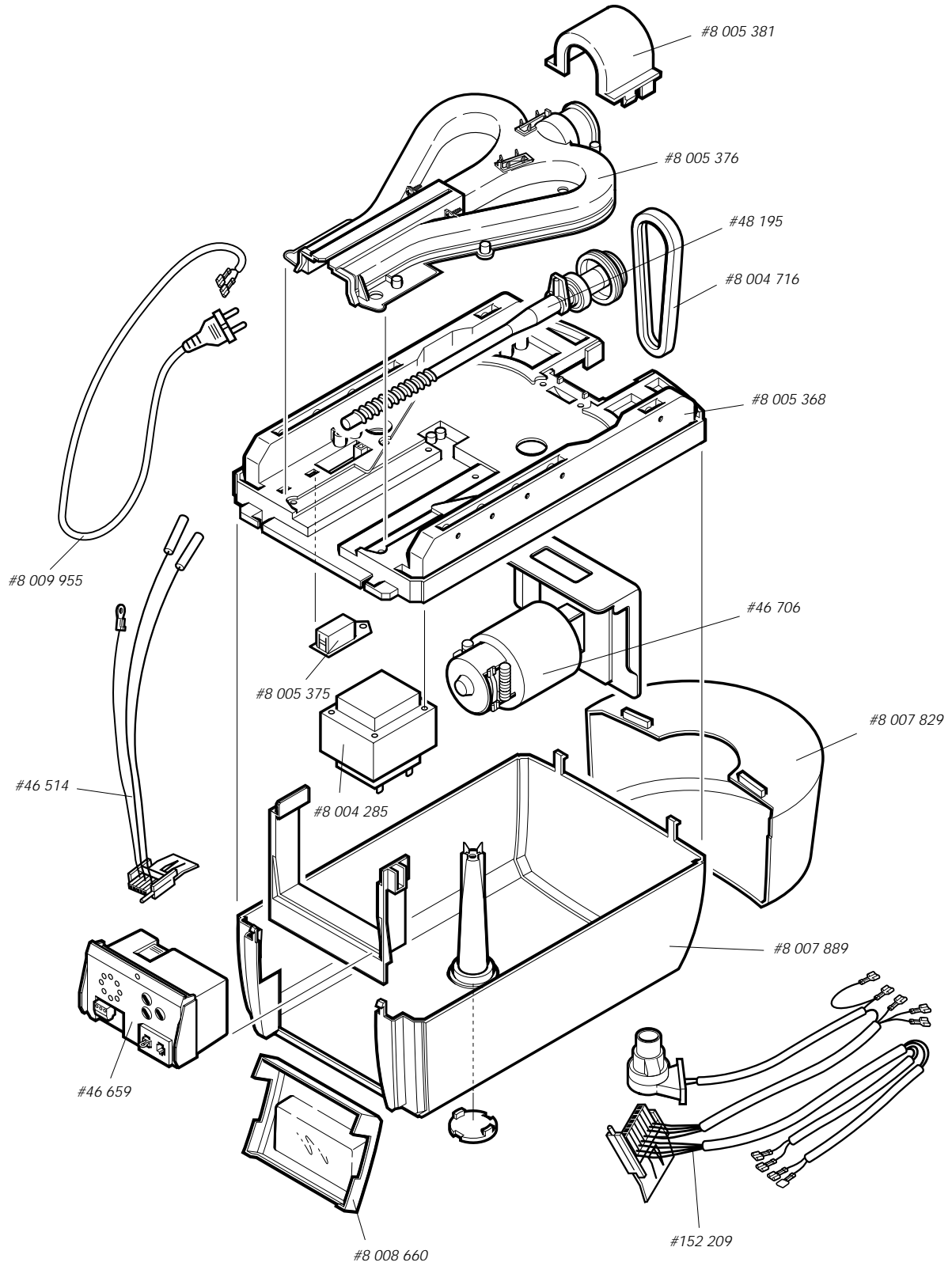

- DEUTSCH** Urheberrechtlich geschützt.
Nachdruck, auch auszugsweise, nur mit unserer Genehmigung.
Änderungen, die dem technischen Fortschritt dienen, vorbehalten.
- ENGLISH** Copyright.
No part of this manual may be reproduced without our prior written approval.
We reserve the right to alter details in the interests of progress.
- FRANÇAIS** Copyright
Toute reproduction même partielle est interdite sans notre autorisation.
Tous changements de constructions permis par l'évolution des techniques réservés.
- NEDERLANDS** Door de auteurswet beschermd.
Niets uit deze uitgave mag worden verveelvoudigd en/of openbaar gemaakt door middel van druk, fotocopie, microfilm of op welke andere wijze dan ook zonder voorafgaande toestemming van de uitgever.
Technische wijzigingen voorbehouden.
- ITALIANO** Diritti d'autore riservati.
Riproduzione, anche solo parziale, previa nostra autorizzazione.
La Ditta si riserva la facoltà di apportare modifiche al prodotto che servano allo sviluppo tecnico.
- ESPAÑOL** Copyright.
Prohibida la reproducción íntegra o parcial sin nuestra autorización.
Reservado el derecho a modificaciones en el interés del perfeccionamiento técnico.
- PORTUGUES** Reservados os direitos de autor.
Reprodução, mesmo parcialmente, só com a nossa autorização.
Sujeito a alterações que sirvam a evolução técnica.
- SVENSKA** Upphovsrättsskyddad.
Eftertryck, även delvis, endast med vårt tillstånd.
Med förbehåll för ändringar som tjänar den tekniska utvecklingen.
- NORSK** Beskyttet opphavsrett.
Ettertrykk - også i utdrag - bare med vår tillatelse.
Endringer, som tjener den tekniske utviklingen, forbeholdes.
- MAGYAR** Szerzői jogvédelem alatt.
Utányomás, kivonatosan is, csak engedélyünkel.
A műszaki fejlődést szolgáló módosítások jogát fenntartjuk magunknak.
- SLOVENSKO** Vse avtorske pravice so zaščitene.
Ponatis, tudi v izvlečkih, je možen samo z dovoljenjem
Spremembe ki so namenjene tehničnemu izboljšanju so tudi pridržane.
- ČESKY** Chráněno autorským právem.
Reprodukování, i ve výtažcích, jen s naším svolením.
Změny sloužící technickému pokroku vyhrazeny.
- POLSKI** Prawa autorskie zastrzeżone.
Kopiowanie, również fragmentów, tylko za zezwoleniem.
Zastrzeżę się wprowadzanie zmian służących usprawnieniu technicznemu.